



REDWOOD

Newsletter of the Redcliffe and District Woodcraft Society Inc.

Editor: Kerry Cameron kandjcameron@gmail.com

Issue No.

286

January 2024

Redcliffe and District Woodcraft Society Inc.

Clubhouse:

Woodcraft Centre
463 Oxley Ave
Redcliffe QLD 4020

Postal Address

PO Box 359
Redcliffe QLD 4020

Club Email: redcliffewoodcraft@gmail.com

Management Committee

President: Ernie Hobson
0400 621 513
erniehobson@outlook.com

Vice President: Graham McDougall
0402 843 197
graham_mcd@live.com.au

Secretary: Ian Ross
0418 378 305
ian.ross200@gmail.com

Treasurer: Richard Scriven
0418 765 643
richscriven@gmail.com

Committee Members

Neil Evans	0438 099 587
Andy McIntyre	0429 317 670
Shona McKay	0408 015 076
Val Millway	0490 501 836
Paul Norton	0427 597 695
Bruce Parker	0402 106 644
Barry Stevens	0408 509 278

PRESIDENT'S REPORT

Welcome to my January report, after our successful break up luncheon, I trust you all enjoyed the break and had a happy & safe time during the recent festive season. I also trust that you are all looking forward to a busy and fruitful 2024.

It has been great to our membership numbers increasing during the last few months and to see a number of them getting involved with committees, sub committees and other allocated duties. Regular attendance, involvement and helping each other will go a long way to make our time enjoyable and rewarding.

Some of our objective for this year are to finish the new extraction shed, install new extraction piping, address the required electrical upgrades, submit several grant applications for much needed machines and equipment, address maintenance issues with our buildings, increase the number of raffle prizes for the Redcliffe Show, add a student section to the show competition, and run refresher courses for our machines.

Be sure to read the Competency Training Program included in this month's Redwood and register your name for refresher training.

Committee and Sub Committees have already met this month and competency training re commenced.

Looking forward to a busy and rewarding year.

Ernie Hobson
President

FINISHING DEMONSTRATION
By Marilyn Kunde. Wednesday 14th Februray

9 am to 12 At Clubhouse

Competency Training Program

Our Competency Training Program is ongoing with training sessions held each month to assist members old and new to maintain their skills to a safe working level.

The training is also a Workplace Health and Safety requirement for our club.

Two or three training sessions are held each month depending on the number of requests for individual machines.

At the completion of training members are given operators status for each machine covered during the training session.

Shown below is a typical Competency Slip indicating the status of members who are operators and assessors. These Competency Slips are located near each machine and are updated each time training takes place for that machine.

Triton Table Router									
Andrew, Graham	26/03/24	Samuel, Sam	26/03/24	Elin, Terison	26/03/24	Robert, Terry	26/03/24	Andrew, Steve	26/03/24
Andrew, Jack	26/03/24	Alan, Alan	26/03/24	Chris, Alan	26/03/24	Carlton, Martin	26/03/24	Samuel, Bill	26/03/24
David, Charles	26/03/24	David, David	26/03/24	Tom, Neil	26/03/24	Greg, John	26/03/24	Robert, Jim	26/03/24
Wing, Michael	26/03/24	Keith, Michael	26/03/24	Edmond, Michael	26/03/24	Langford, Bob	26/03/24	Wesley, Robert	26/03/24
William, Tim	26/03/24	McDonald, Andrew	26/03/24	McNary, Andy	26/03/24	Simon, Paul	26/03/24	Taylor, Stuart	26/03/24
Wright, Neil	26/03/24	Willy, Mike	26/03/24	Robert, Alan	26/03/24	Robert, Peter	26/03/24	Alan, Ian	26/03/24
Wright, Barry	26/03/24	Woodward, Lawrence	26/03/24	Wright, Roger	26/03/24	Thomson, Terry	26/03/24	Taylor, Stuart	26/03/24
William, Ian	26/03/24	Thomson, Walter	26/03/24						

If the date next to your name falls before the next Refresher Training Date (March Annually) then Operator Status will be cancelled automatically on the date shown. To regain Operator Status please register your name in the Request for Training Book.

The Operator/Assessor Status remains current for 3 years from the last date of completed training. To maintain operator status members must complete a refresher session for each machine before the 3 years expires.

Refresher training sessions are held early in each year. The scheduled dates for 2024 are the 26th and 28th March.

All members are responsible for their own checking of the competency slip and nominating for the required refresher courses.

Drawing ZENTANGLES by Barry Spillman

Just use pencil (pen) and paper to draw this zentangle.

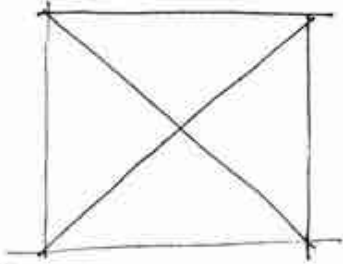

Draw a square, then the diagonals.

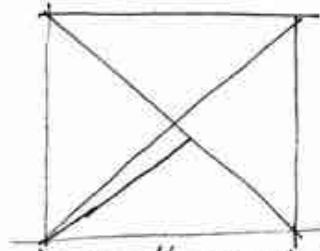

Draw the next line.

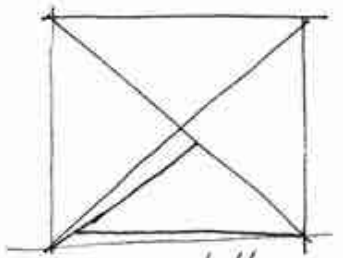

... and the next.

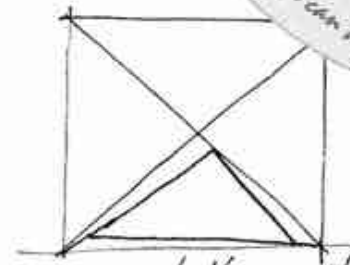

... and the next.

Anyone can do it!

Tip: Turn the page to a comfortable position as you draw each line.

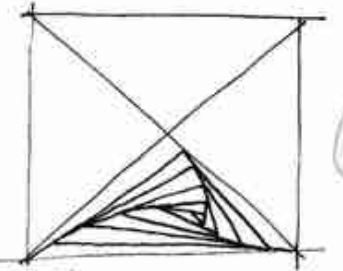

Continue drawing lines.

Good for the mind.

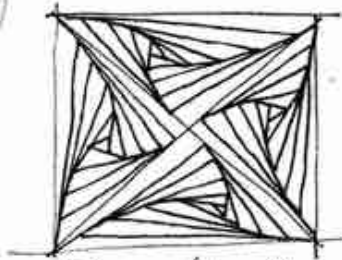

Repeat in the other three triangles.

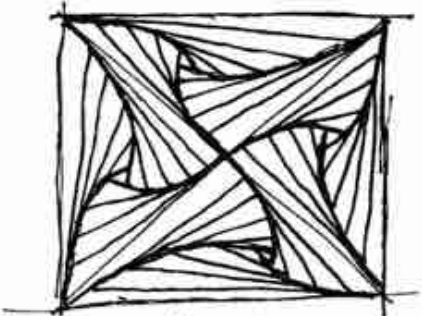

Highlight some lines.

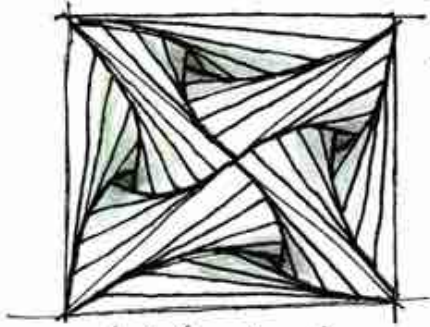





Add shading.

7/5/24

Please 'LIKE' our Facebook pages

As you know we have a **members only** 'inward facing' Facebook page that any member can join and only members can join and post to it.

We also have an 'external facing' Facebook page where only the 'administrator puts up posts. This Facebook page has been created to promote the great things our club does and to show our 'potential' sponsors the coverage they can get by supporting us.

EXTERNAL Facing Facebook	INTERNAL Members only Facebook
<p>Sponsors want to see a well-supported page and to have that we need our members to simply 'like' and 'follow' this page:</p>	<p>Go to Facebook and search for Redcliffe Woodcraft Society Members. The one that looks like this – with all the members pictured.</p>
	 <p>When you find this page on Facebook you need to request to join the group – that is because it is a private group. I have put an example of what you might see below (obviously not our page – just an example of what it looks like). There is a bar – that says 'Join' – click on that bar. A request will go to Shona for her to approve – and then you can post to the page.</p>
<p>As you can see we only have 9 followers at the moment. Please follow our page and encourage your friends on Facebook to follow the page. Please go to the Redcliffe Woodcraft page on Facebook. (The one directly above – no people in the photo) Click on the 'like' button – like in the picture below.</p>	
 <p>Click the 'like' button or the 'Follow' button – whatever you see. This means that you will see the posts that go up and you can comment on them and 'like' the posts. Important that you do this regularly. Only Shona can post to this page..</p>	 <p>If you have a problem with either of the Redcliffe Woodcraft pages see Shona.</p>

Experimenting with Resin casting



Some years past I read an article on turning paper that had been caste in a mould bonded with resin, my interest was rekindled recently by another article that talked about tuning a platter using the paper laminated with resin technique. My idea though was to start off small and caste some pen planks with layers of paper.

I made a sacrificial casting bed from thin offcuts glued with hotmelt, instant construction and forms a good sealed joint.

Photo #1 stripped colourful glossy paper, first mistake, as the resin did not permeate the paper and when it was turned the blank separated **Photo #2**



Not to give up I than selected a coloured newspaper insert and some of Jo's quilting offcuts, randomly shredded into separate containers **Photo #3**



Using blue tinted resin with the paper and red for the cloth I caste two new pen blanks **Photo #4** allowing them to cure for two days before cutting out of the sacrificial mould **Photo #5**

Two pens were then turned successfully, buffed and polished with cutting compound and a final buff of Carnauba wax.

Photo #6



Conclusions:

I have used the West System 5/1 resin for many years for small castings and highlights in woodturning and furniture and the casting quantities need to be controlled as larger pours tend to overheat and creates bubbles. I mix the resin in 20mm batches to minimise over-heating.

Layer the paper or cloth ensuring that the resin fully permeates and is evenly distributed during the casting process.

For this experiment I tinted the resin red for the cloth and blue for the paper for my next caste I will not tint the resin.

It has been an interesting and fun exercise and has future potential.

I have also caste other pen planks with wood and tinted resin that make interesting pens.

Kerry Cameron





The RDWS annual WOODCRAFT COMPETITION is held in conjunction with the Redcliffe Show. We have 13 classes for members to choose from to submit entries into. A maximum of two per class and the entry must have been made within the past two years. It is a great opportunity to get feedback from a juried competition for both experienced and beginners.

A competition booklet will be available shortly, in the meantime start preparing your entries and let's make it a year to remember.

Our Show committee is chaired by Neil Evans.

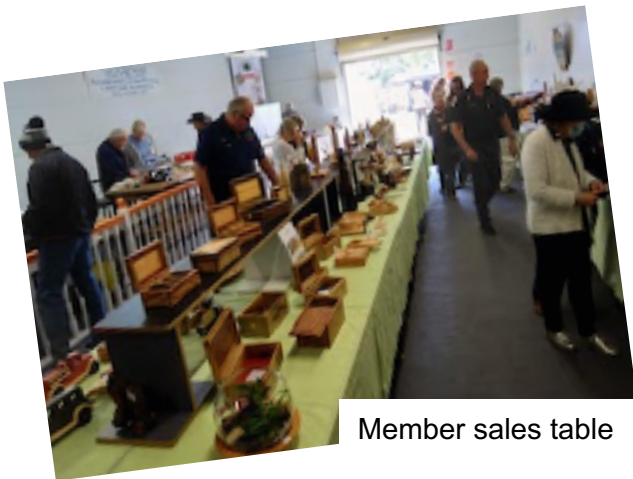

Member sales table



Competition entry display



Member demonstrations of woodcraft disciplines



Show and Tell (Jan 24)



A selection of tissue boxes by Ernie Hobson



New to turning Maureen Kowalski proudly showed her recent creations



John Picard's cat in camphor laurel



Ken Rays miniature lidded boxes with traded lids, beautifully created.



The setting out/up of Ken's three off centre bowls and the finished item in mallee burl. A brilliant concept and execution.



Kerry Cameron had two shallow bowls turned from the fork a red cedar tree, one had been 'stitched up' where he had gone through the side.



The small bowls turned from the regrowth stump of a white cedar tree that had been cut down by Kerry. The raw timber is shown above



Marilyn talked about the difficulty she had trying to hold the odd shaped hairy oak drilling out the recess for the candles



Everyone wanted to have a look and talk about the items on show for show and tell



The Lute has now been added to our musical instrument makers list with one of our newer members John Gorrett sharing his expertise in the instrument's construction.



Warrick King and Daryl Stephenson improving the ducting system to the lathe area



Maureen Kowaiski honing her woodturning skills

TIPS AND TRICKS borrowed from Magazines available from Moreton Bay Library via the Libby App.



▲ The V-jig works well for any odd shaped pieces, such as when notching or ripping dowels.

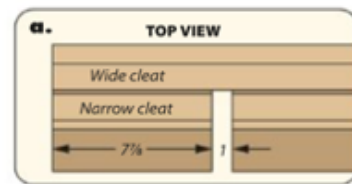

Band Saw V-Jig

Cutting odd-shaped parts always poses an interesting challenge. The band saw is certainly the safest place to get the job done, but it's far from perfect. That said, this V-jig will certainly help when it comes to long workpieces.

The jig cradles the piece, and it works well for a few different operations. Two cleats are mounted on a hardboard base to create the V. A notch into the jig separates the narrow cleat and allows room for the band saw's blade. As you can see above, the jig gets taped to the fence, and the V supports pieces of any shape.

*Leonard Wade
Lake Charles, Louisiana*

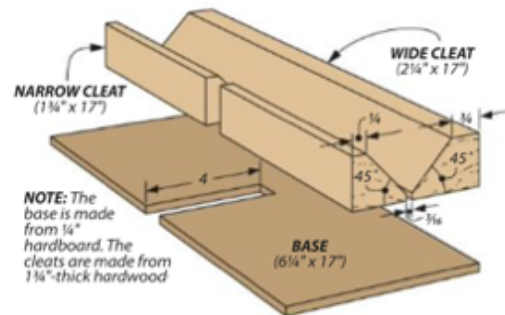

A good example for the use of a **Metal Detector**.

*Contributed by Graham
Anderson*

SPONSOR HONOUR LIST

Please give your support to these businesses because they support our Club



All Ways Glass & Glazing 2/297 Macdonnell Rd, Clontarf 4019	07 3284 4299	
Aussie Escape Caravan Repair & Service Specialists 40 South Pine Road, Brendale 4500	07 3205 7738	http://www.aussieescapecaravans.com.au/
Abrasiflex Unit 1 22/24 French Avenue Brendale Qld 4500	07 32937001	www.abrasiflex.co.au
Combined Saw and Knife 105-107 Kabi Circuit, Deception Bay 4508	07 3204 0977	https://combinedsaw.com.au/contactus
Ernie's Electrical Service 13 Hughendon Crt, Deception Bay 4508	07 3204 9866 0419 388 945	https://ernieelectricalservice.business.site/
Lindsay Meyers 11 Grice St, Clontarf 4019	07 3284 5281	http://www.lindsaymeyers.com.au/
Moreton Bay Regional Council PO Box 159, Caboolture 4510	07 3205 0555	https://www.moretonbay.qld.gov.au/contact/
Utopia Woodcraft , Marilyn Kunde 31 Beech Drv, Cashmere	0403216317	email: zakk@tpg.com.au
Red Poppy Art Collective 95 Redcliffe Pde. Redcliffe 4020	0455963554	www.redpoppyart.com.au
Signs & Designs 3/16 Paisley Dr, Lawnton 4501	07 3205 4544	http://www.signsanddesigns.com.au/
Stevie Redback Pest & Termite Control Unit 4 66-67 Snook St Clontarf 4019	1300 665 665	https://stevieredback.com/
The Tradesman's Toolbox Unit 1,1 Garfield Street, Morayfield 4506	07 549 8000	https://tradesmanstoolbox.com.au
Sunstate Timbers 72 Lipscombe Rd, Deception Bay 4508	07 3204 2533	http://www.sunstatetimbers.com.au/
Traditional Funerals 17 Anzac Ave, Redcliffe 4020	07 3284 7333	https://www.traditionalfunerals.com.au/
Vicmarc Machinery Pty Ltd 52 Grice St, Clontarf 4019	07 3284 3103	https://vicmarc.com/

The Redcliffe and District Woodcraft Society Inc. - General Information

The aim of the society is to promote, foster and practice the art of woodcraft and kindred arts. As at 30 June 2023 the Society had 119 financial members. Meetings and Workshops in woodturning, woodcarving, scroll sawing, pyrography, general woodworking, timber preparation and musical instrument making are held in the Woodcraft Centre at 463 Oxley Avenue, Redcliffe. The Society is administered by a Management Committee of eleven members who report to the general membership.

Members meet on Tuesdays for general workshop activities. Members also meet on Wednesday, Thursday and Friday mornings.

The Society has a large range of tools and machinery for members use and offers regular tuition in different aspects of woodcraft. Less experienced members are tutored by more experienced members in a self-help program that is sponsored by the Society.

The Society also conducts a comprehensive system of competency in the operations of its machinery. ALL NEW MEMBERS ARE WELCOME